

PART TWO. -- THE THREE-PHASE INDUCTION MACHINE AS A GENERATOR.

As was said earlier, there are two principal types of rotating machines that generate AC power, the synchronous generator, and the induction generator. The synchronous machine has long been dominant in the power industry. Induction generator technology has been in use for many years as indicated by references [8] & [9] from 1935 and 1939. However, the induction generator practically disappeared in the 1960's [1].

Since the energy crisis of the 1970's, the increased emphasis on renewable energy has caused a great interest in the development and use of alternative energy sources, such as wind and micro-hydro plants. The induction generator is now seen more frequently, especially in the "co-generation" field. Congress passed the Public Utilities Regulatory Policy Act (PURPA) in 1978 in response to oil shortages and the resultant price spikes that threatened the U.S. economy. Before that act, utilities were reluctant to allow small hydro producers to connect to their grid. PURPA required that utilities buy energy from Independent Power Producer Facilities ("IPPs") at rates established (in Colorado) by the Colorado Public Utilities Commission (PUC). These rates reflected the "avoided cost," or the cost the utility could avoid by not building and operating an equivalent fossil-fuel power plant, because the utility received capacity from the IPPs. The City of Boulder, CO has installed seven grid-connected hydroelectric plants on its water supply pipelines to reduce high water pressure and generate electrical energy as a by-product of the municipal water system operation. Most of the energy is sold to the local utility Xcel Energy.

For the City of Boulder, the payment from the utility consists of two parts:

- An energy payment (about 2¢ per kWh), e.g., coal, salaries, maintenance.
- A capacity Payment (\$17.65 per kW-month), which represents the cost to build the new plant.

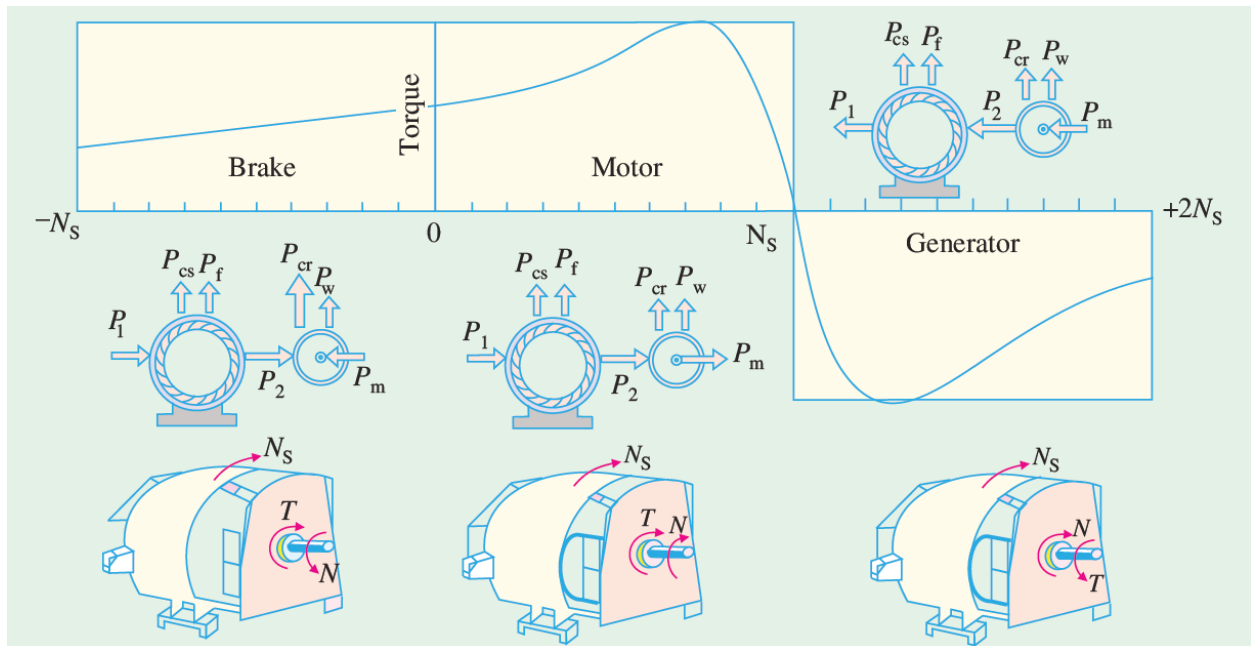

Figure 1 -- Induction machine operating regions. [3]

GRID CONNECTED INDUCTION GENERATORS.

For the small unattended grid-connected hydro plant, the induction generator with its low maintenance, ruggedness and simple control schemes was the ideal application. Four of Boulder's seven constructed hydro plants use induction generators ranging from 75 kW to 800 kW. The city received over \$2,000,000 in hydropower revenue in 2016 from all the facilities [4].

So far, we have only discussed the motoring part of the induction machine torque-speed curve. There is also a **braking region**, in Figure 1 to the left of the motor region, in which the slip is greater than 1. This implies that the rotor is rotating in the opposite direction of the stator field. Switching two of the leads on the three-phase supply to the stator initiates braking, and will stop the motor very quickly, which is hard on the motor due to the high currents.

In the **motor region**, the mechanical speed lags the synchronous speed ($n_m < n_{sync}$), i.e., the rotor is dragged along behind stator flux. The slip creates a rotor flux with magnetic polarity opposite to the stator. The motor region slip is between 1 (starting) and zero (synchronous speed), although the motor slip never quite reaches 0. At a slip of 0, $n_m = n_{sync}$, and the machine is neither a motor or generator. The induction generator always consumes reactive power to establish the stator rotating magnetic field, regardless of whether it is operating as a generator or a motor. At synchronous speed, the line supplies reactive power and machine losses, but no torque or power is generated.

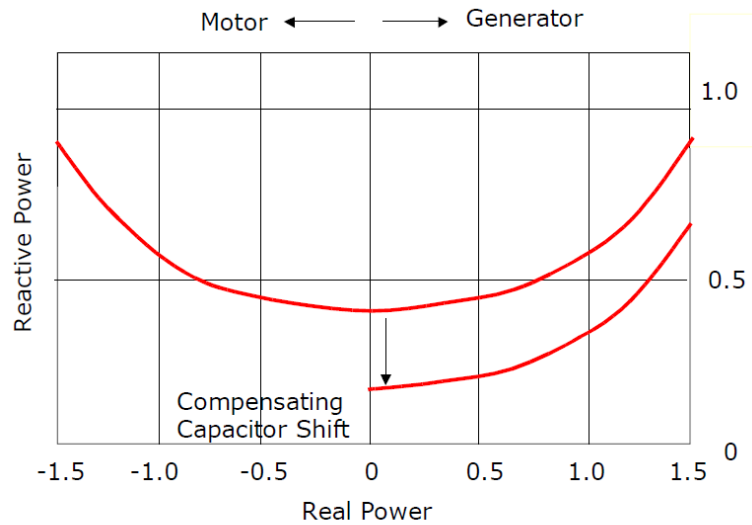

Figure 2 – Asynchronous Capacitor compensation [17].

In the **generator region** to the right of the motor region, the shaft and rotor is being driven by a mechanical prime mover faster than the stator field, ($n_m > n_{sync}$) while connected to an AC system. The prime mover can be a turbine, an engine, a windmill, or anything capable of supplying the torque and speed needed to drive the motor over synchronous speed. This power is delivered across the air gap to the stator, and from the stator to the line [1]. So, the induction generator is just an induction motor which is driven faster than the synchronous speed. The slip speed is negative, since slip speed $n_{slip} = n_{sync} - n_m$. An increase in rotor speed above n_{sync} causes a reversal in relative direction of rotation between the rotor bars and the stator flux, and the induced rotor voltage and current direction are correspondingly reversed. The rotor then induces a voltage into the stator due to the rotor conductors cutting stator magnetic field. Shaft torque, supplied by the prime mover, is transferred across the air gap to the stator, where it is delivered to the system as generated power. As the input mechanical power is increased, and the generator's rotor speed continues to increase a few percent above synchronous speed, more electrical energy is produced. When running as a generator, the machine takes reactive power from the AC power line and supplies active power back into the line. The active power supplied back in the line is proportional to slip above the synchronous speed. The torque,

current, efficiency and power factor of the generator operating at a given slip speed above synchronous speed will be similar to when the machine is operating as a motor.

Induction motors can be used as generators. However, many times the nameplate voltage for a nominal 480-volt motor is 460 volts, to make up for line losses. An induction generator should have a higher voltage rating than the bus voltage, i.e., 500 volts because the generator is now the power source rather than being a load on the power system. [1]

Better understanding of the induction generator may be gained by examining the differences between the two primary types of AC generating machines, synchronous and induction:

- A synchronous generator is capable of being the isolated source of power to a given load or section of a power system. To generate power, the induction generator is usually connected to an energized AC system with synchronous machines. As discussed later, it is possible to have capacitors connected across its terminals to supply the necessary magnetizing current for field excitation.
- A synchronous generator is capable, by virtue of its variable field, of taking part in the control of system voltage and power factor. Since the induction machine depends on the system to which it is connected for its excitation, it is incapable of any voltage regulation.
- A synchronous machine always rotates at synchronous speed. An induction generator's frequency is the same as the system's frequency. However, to generate power, the induction generator's rotor must be driven at a speed a few percent greater than that associated with the system frequency. A governor is not required for frequency control.
- The rotating field in a synchronous generator is made up of pole pieces which are separately energized electromagnets. The rotor of the induction generator is generally of the "squirrel-cage" type.

Reference [1] compares the induction motor and generator equivalent circuits, the phasor diagrams, recommended studies to interface with the public utility, and items to consider when specifying an induction generator.

Inrush and compensation.

Inrush. Like the induction motor, when an induction generator is connected to an energized line, there is a large inrush of reactive current to magnetize the generator's iron and coils. This current flow is large enough that the system to which the generator is connected must be very stable, to tolerate the resulting voltage "dip."

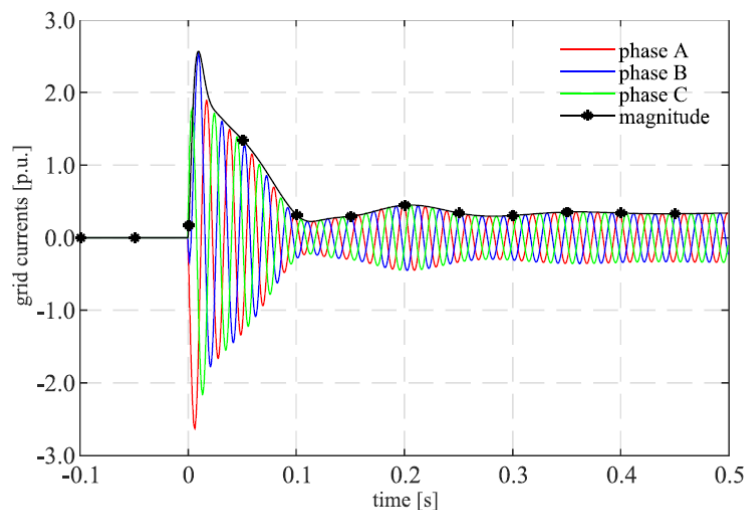
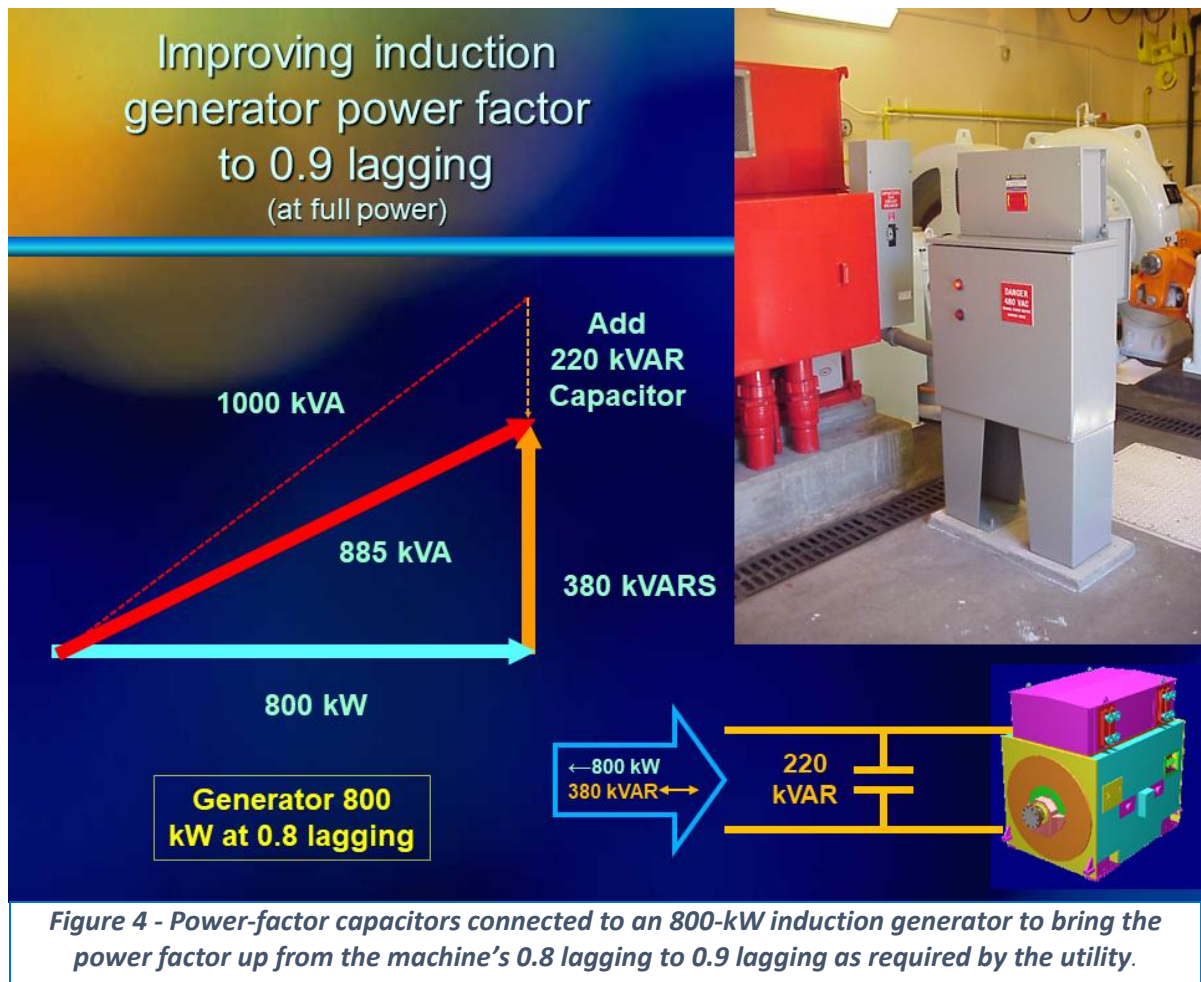

Figure 3 -- Simulation results showing inrush currents for direct grid connection of the induction generator [18].

Compensation. Also, the induction generator, by its nature, has an inductive effect on the system and will draw large amounts of lagging current from a distribution network. To compensate for this heavy VAR load, it is easy and economical to connect shunt capacitors near the generator terminals to improve the power factor [1] (Figure 3). Since capacitance generates VARs, the inrush spike can be somewhat counteracted immediately. With the generator running, the capacitors improve the power factor of the machine. Commonly, utilities may demand 0.90 or 0.95 lagging power factor instead of the typical 0.8 to 0.9 lagging power factor of an induction machine. Any power factor less than unity means that the utility is supplying more “wattless” power, and they may penalize facilities whose power factor is below their requirement. However, these capacitors should be disconnected from the generator when the unit is taken off-line and re-connected a second or two after the generator comes on-line. Especially with hydroelectric turbines, there is a period of overspeed after the loaded generator is disconnected from the system, which can cause dangerously high terminal voltage if the generator is self-excited by the capacitors. This high voltage may be a human hazard as well as damage the insulation. For this reason, most external capacitance is removed when the unit trips off, and the prime mover’s torque is reduced as soon as possible.



Like the induction motor, the generator's power factor will be poor at light loads since its magnetizing power is fairly constant regardless of load. Therefore, it should be run close to full load [1].

Except as noted in the self-excited generator section below, the induction generator is generally considered to be unable to generate voltage in isolated conditions, and so must operate in parallel with another source of reactive power.

Classification by size. Electric generation with capacity 5 kW-100 kW is classified as micro- and below 5 kW is classified as pico-generation. DOE defines small hydropower plants as projects that generate between 100 kilowatts and 10 MW, and large hydropower plants as facilities that have a capacity of more than 30 megawatts (MW). Induction generators are used up to about 2 MW.

Induction generator advantages and disadvantages.

Induction generators have the following advantages:

- The lack of excitation equipment means that the induction generator construction is brushless, so operation is much simpler, and it requires less maintenance.
- Since the induction generator does not require elaborate synchronizing to connect it in parallel with other generators, the cost of control equipment is reduced. Bringing the induction unit on-line is much easier than the synchronous unit. A common start-up procedure for the induction unit might be:
 - Use the prime mover to accelerate the generator to approximately synchronous speed (95% to 105%). When the rotor is running at synchronous speed, the slip, the net torque and the rotor current will be zero.
 - Close the generator circuit breaker to connect the generator to the line.
 - Increase unit's load until it is carrying the desired load. The speed will increase by a few rpm.
 - If power-factor correction capacitors are used, connect them after the generator has been on-line for a few seconds.
- The induction generator will not contribute sustained short-circuit current. If the system voltage is lost, there will be no excitation and the unit voltage will fail.
- The induction machine is much less likely to "sip a pole" and fall out of step with the system than the synchronous machine.
- The rotor is more sturdily constructed, there being no salient poles attached.
- The induction machine can be easily operated as either a generator or motor.
- The cost of the induction generator and controls is about 10% lower than a synchronous generator [1], although the need for power-factor correction capacitors may offset some of that savings.
- They are available in a wide range, from a few kilowatts to around two megawatts.
- Since the induction generator is brought up to speed by the prime mover, a low slip design can be utilized to increase efficiency. Care must be taken to synchronize carefully, as the available rpm window for closing the breaker is small.

The induction unit has several disadvantages:

- A high inrush of current is required when the generator circuit breaker is closed to magnetize the iron and establish the excitation. This severe spike could be intolerable to the connected utility, as it pulls down the voltage momentarily. However, the cities of Boulder and Denver have successfully used direct on-line starting with induction generators ranging from 69 kW to 2 MW.
- Slower speed units, such as those driven by small hydro turbines, present an even greater power factor problem than the higher-speed units.
- The size limit of an induction generator is about two megawatts, due to inrush current causing a dip in the supply voltage.
- The power factor is determined by the load power factor. The induction unit cannot produce reactive power (VARs). Therefore, the induction generator can do nothing to correct the system voltage profile.

Figure 5 below is from an acceptance test of an 800-kW induction generator for Sunshine Hydro plant in Boulder, CO. This machine has a rated power factor of 0.8 lagging. The utility requires 0.9 lagging.

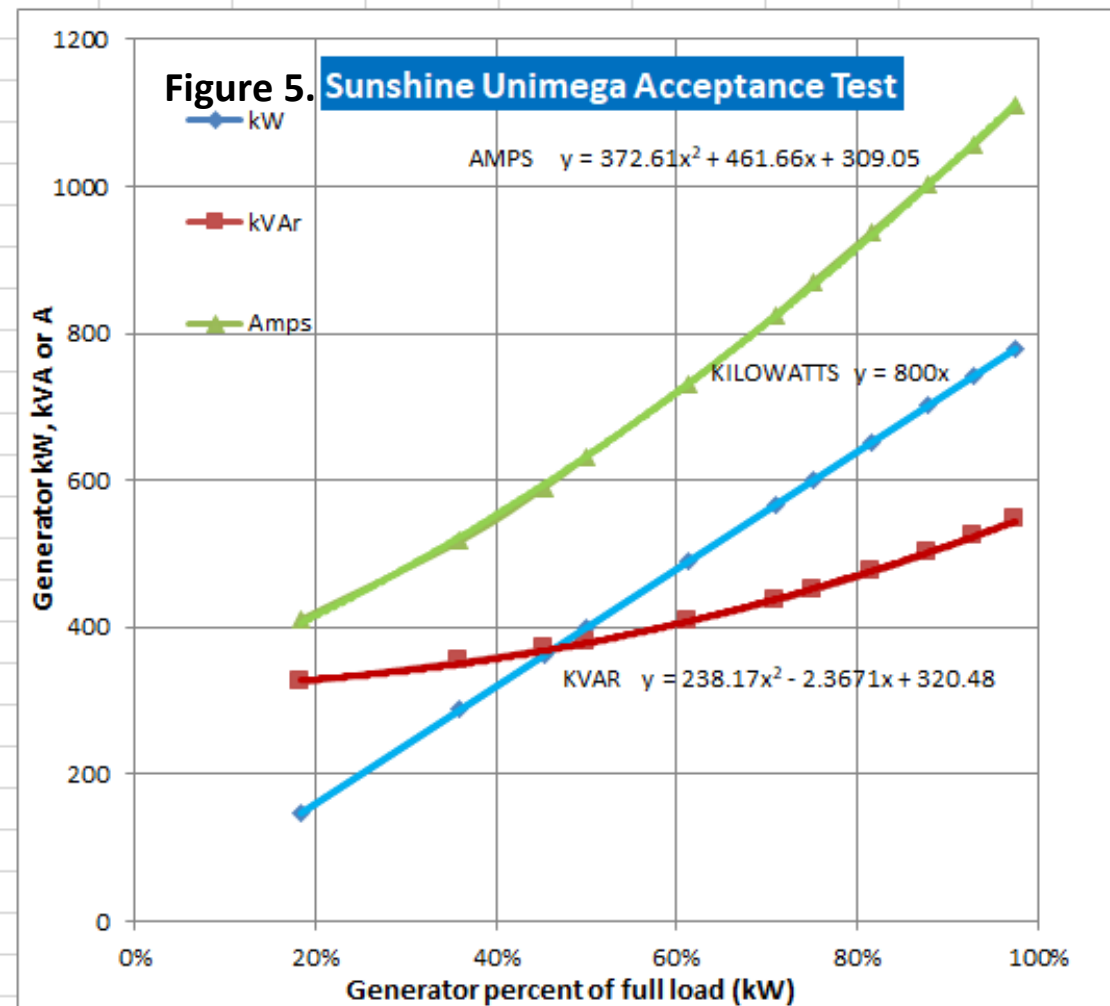

Figure 4 shows that 220 kVAR of capacitive correction are required. Note from the “amperes” and “kVAR” curves in Figure 5, that the no-load reactive excitation current is 309 Amperes, corresponding to 320 kVAR. This no-load excitation current can be calculated to be 29% of the full-load current.

Reducing the inrush current. Starting an induction motor or generator with a soft starter increases the voltage supplied to the induction machine gradually. Back-to-back switched thyristors are applied in each phase to apply a three-phase controlled voltage to the induction machine. Figure 6 shows the firing circuit which controls the thyristor firing angle and thus the magnitude of the inrush current during starting. The machine magnetizing flux builds up gradually and the generator output is increased until the machine is generating the desired power. Once the machine is at the desired operating level, the thyristors are bypassed.

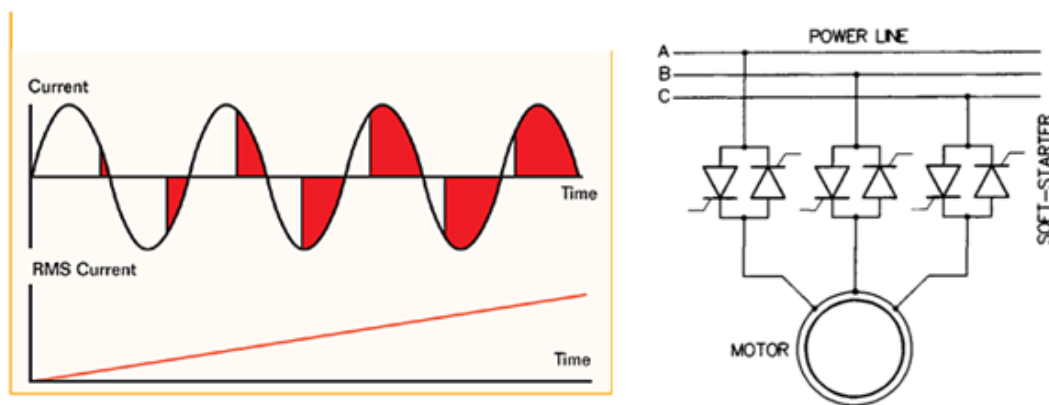

Figure 6 – Thyristor soft starter for motor or generator. Figure credit :Motor Starter, ElProCus Technologies Pvt Ltd., <https://www.elprocus.com/motor-starter/>

Another method to reduce inrush current is to use reactors instead of thyristors, which may cost less in comparison with other starting methods. Power is supplied from the power source side to the generator through a reactor and switch S1 at about 95% speed. This speed condition is called motor mode. After several seconds, the switch (S2) installed in parallel with the reactor is closed to bypass the reactor [5].

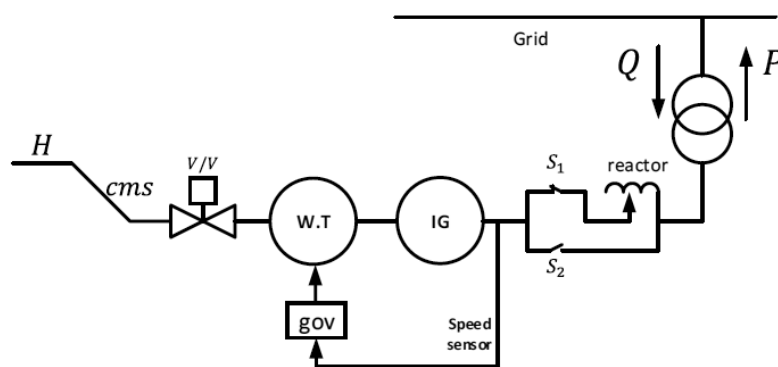

Figure 7 – Schematic diagram for a small hydro power plant using a reactor soft starter. [5]

Connecting to the grid. A grid-connected induction generator requires a prime mover like a water turbine to be a source of mechanical energy. A generator converts this rotating torque into AC electrical power. Switchgear provides a point of interconnection where the customer-owned equipment interfaces with the electric utility's distribution system. Applicable utility technical requirements for equipment and operation will need to be met. The electricity must be of sufficient quality to meet utility requirements, disconnect quickly and safely from the grid when a disturbance is detected, and reconnect (either automatically or with operator intervention) when it is safe to do so. The customer's protective devices need to be coordinated with the utility's protective relays and reclosers.

Protective relays detect abnormal conditions, including short circuits and overloads, and operate circuit breakers to isolate the malfunctioning system components, preventing damage to the generator and to transmission and distribution system components. Many protective relays now use solid-state electronic components controlled by microprocessors. Many of the functions of discrete relays can be incorporated in a single package. Several internationally recognized standards, including several IEC standards and the IEEE 1547 family of standards, guides, and recommended practices, are commonly used or referenced as part of interconnection processes. One of the key technical standards widely used for grid interconnection is IEEE 1547-2003, Standard for Interconnecting Distributed Resources with Electric Power Systems. [6]

The devices in switching apparatus are referred to by numbers, with appropriate suffix numbers and letters when necessary. These numbers identify the features of a protective device, such as a protective relay or circuit breaker, and are based on a standard system adopted for switchgear by IEEE and incorporated in ANSI/IEEE Standard C37. Some of these device numbers are shown in the protective relay example below, which shows the protective relays required by the local utility for a 10 to 100 kW system. Since these stations may be unmanned, some relays can trip a 94 relay which trips the breaker, but does not latch or require a manual reset, and may permit automatic restarting after a time period. Examples of these relays are: 81 O/U, and 27/59. Other relays like 32, 47, 49 (thermal) and 51 should trip an 86-lockout relay, which requires a station visit and needs to be manually reset.



Figure 8a -- 86 lockout relay

The example below shows the basic protective devices to protect the generator and equipment from the utility's point of view. Many other functions need to be monitored to have a complete protection system for the induction generator station. Examples include, flood (water on the floor), hydraulic pressures (high and low), failure to start within a time period, turbine vibration switch, transformer protection (differential, temperatures, overpressure), watts and vars, battery undervoltage, lockout relay status, turbine speed, water flow and pressures, RTD winding temperatures (generator and bearings), intrusion, and valve status (open/closed).

Figure 8b –An example of utility Interconnection requirements [7]

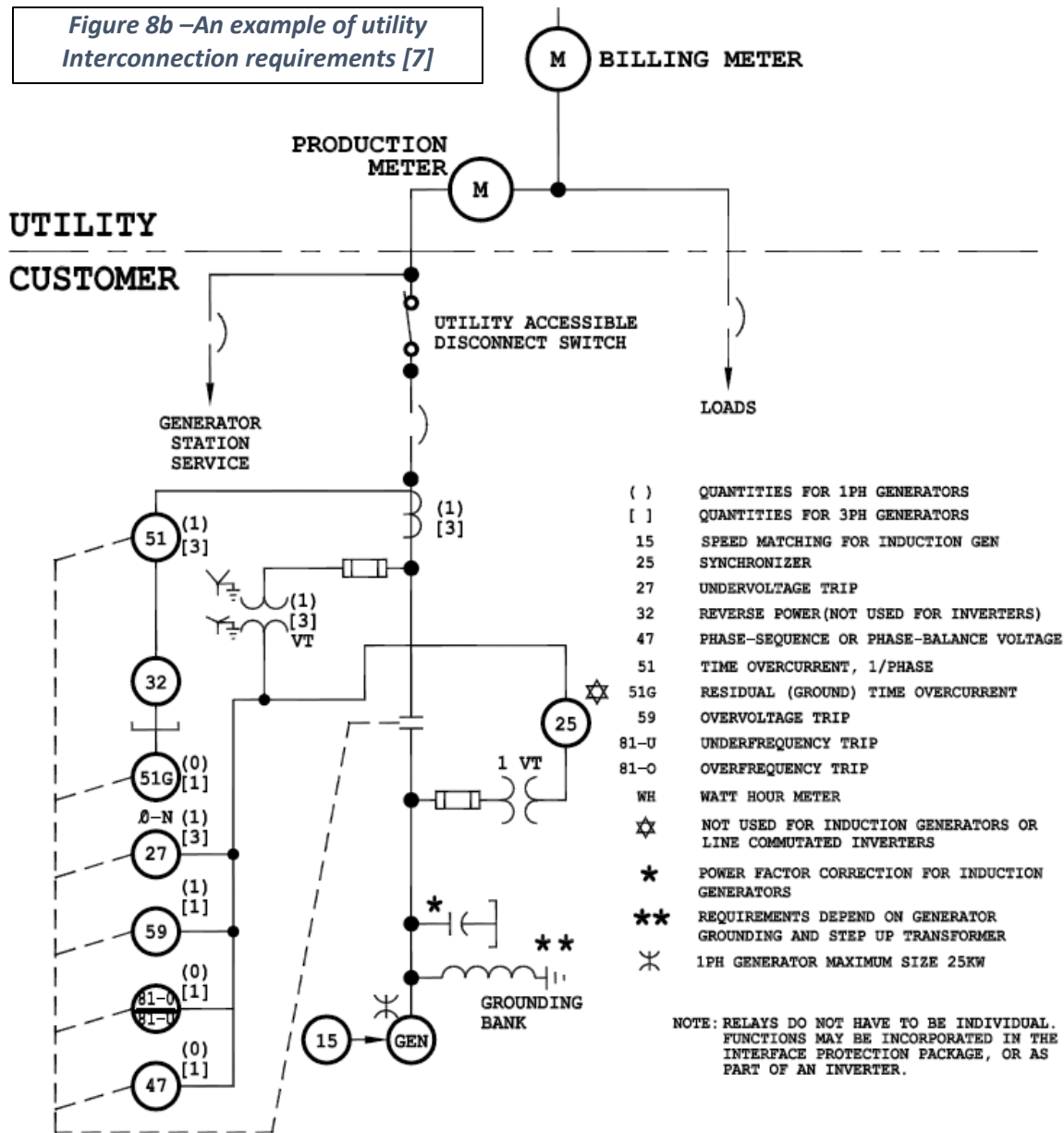

UTILITY GRADE OR HIGH QUALITY INDUSTRIAL GRADE RELAYS

3/15/2010



TYPICAL PARALLEL GENERATION
 INSTALLATIONS 10kW TO LESS THAN 100kW
 URBAN CONDITIONS

FIGURE NO.
10.2A

SELF-EXCITED INDUCTION GENERATOR (SEIG).

The SEIG concept has been around for a long time, as indicated by a 1935 technical paper *Capacitive Excitation for Induction Generators* by Basset and Potter [8], and *Self Excitation of Induction Generators* from 1939 by C.F. Wagner [9]. When generators are connected to a supply grid, they are called grid connected induction generators and when they are not connected to supply grid, they are called self-excited induction generators. Three-phase or single-phase induction motors can operate as induction generators independently of the grid when driven by external mechanical power and when they are

compensated to the point of self-excitation by adding capacitors to supply the magnetizing current. In other words, the lagging volt-amperes of excitation must equal the leading volt-amperes of the capacitors. Small induction generators with excitation capacitors are commonly used throughout the world for small power sources, like pico- and micro-hydro and wind, using small motors (50-100 watts) up to a few kilowatts. In these applications, simplicity and low cost is paramount, and stable output voltage is not a primary concern.

A single-phase induction motor operated as a SEIG can supply single-phase loads, but almost all the commercially available single-phase induction machines are 5 hp or less. If you need more than a few horsepower, three-phase machines can be used for single-phase power generation. Three-phase motors are more efficient, and manufacturers make them in ratings of hundreds of horsepower. The current of the three-phase SEIG used for supplying single-phase loads is extremely unbalanced, and therefore, a three-phase machine needs to be derated to 80% to keep the temperature of the machine within allowable limits, unless the C2C method is employed (below).

When used for balanced three-phase generation, the induction generator has the same advantages that three-phase motors have over single phase, as discussed before. However, most of these small applications do not have three-phase loads, it is difficult to keep the phases in balance, and an extra conductor is required so generators that produce single-phase output are used [10].

The self-excited induction generator disadvantages are:

- Poor voltage and frequency regulation. The voltage fluctuates with the load. The frequency is proportional to the rotor speed minus the slip speed. To maintain constant frequency, the rotor speed must be increased by the slip speed, which varies with load. Overvoltage relays must disconnect the load and the capacitors to avoid excessive voltage in runaway conditions [10].
- If the induction generator is used to drive a motor, the inductance of the motor will cancel out the capacitive reactance of the capacitors and cause the generator to quit producing electricity unless the induction motor is compensated to unity power factor by capacitors.

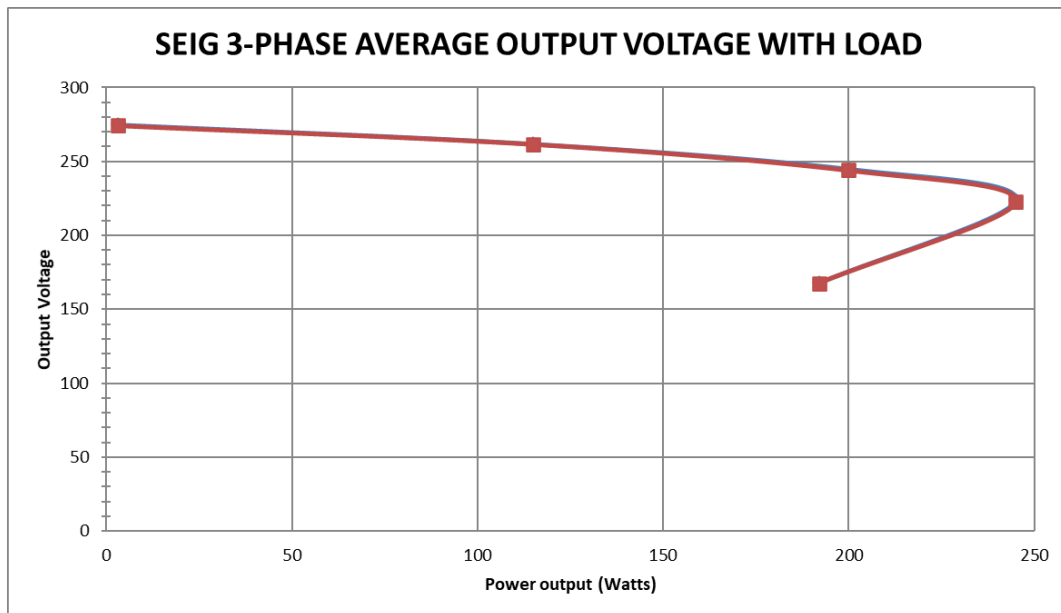

Figure 9-- SEIG output voltage varies with the load [Chart by the author]

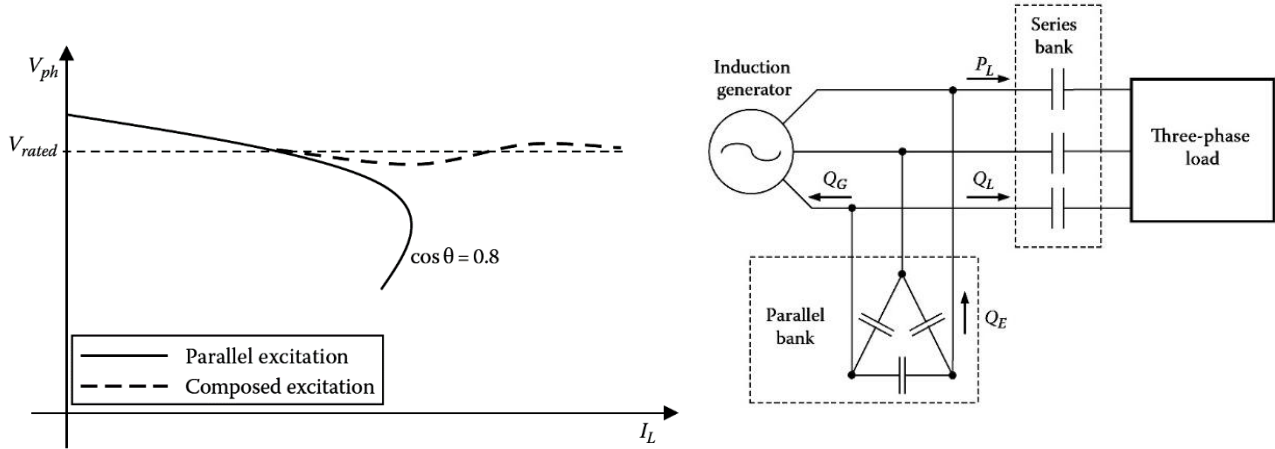
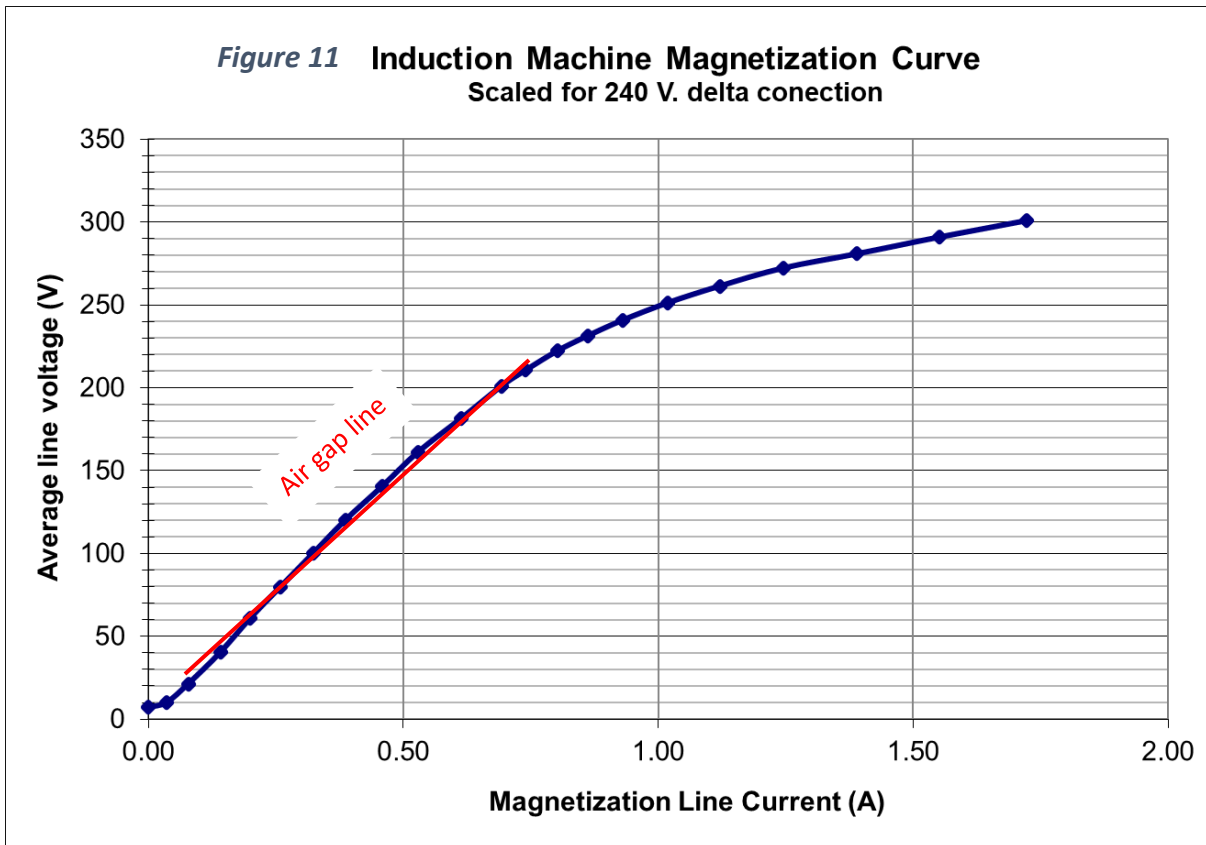

Figure 10 -- Improved SEIG voltage characteristics by adding a series capacitor bank.[2]

The voltage characteristic of the SEIG can be improved by adding a bank of capacitors in series with the generator output as shown in figure 10 [2].



Performance of the SEIG. The following examples use the following lab machine: 6-winding (parallel connected), squirrel cage induction, 60 Hz, 1/3 HP, 208 Volts, 3.1 Amps, speed 1725 RPM (as a motor).

How to determine the necessary capacitance for the SEIG machine. First, what happens when excitation capacitance is connected to the induction machine operating as a SEIG? The induction machine has a magnetization curve shown in Figure 11 (terminal voltage vs. magnetization current). The magnetization curve of the induction generator is nonlinear due to the core's magnetic saturation. This generator reactive power requirement must be satisfied by the capacitors.

The hard way to determine C: To obtain the magnetization curve, the induction machine is driven by a synchronous motor without load, and the current is measured as a function of the applied terminal voltage, starting at the residual magnetism value. The few volts initially generated are due to this residual magnetism when the rotor of the induction machine turns with no voltage applied. Without residual magnetism, the self-excited induction generator cannot produce any voltage. The linear portion of the curve is the air gap line.

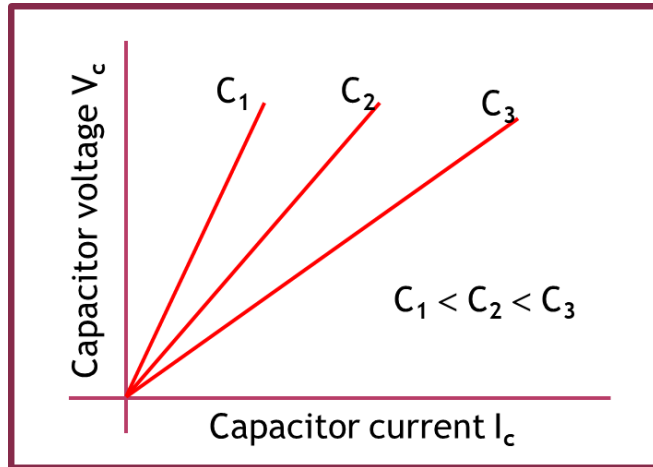
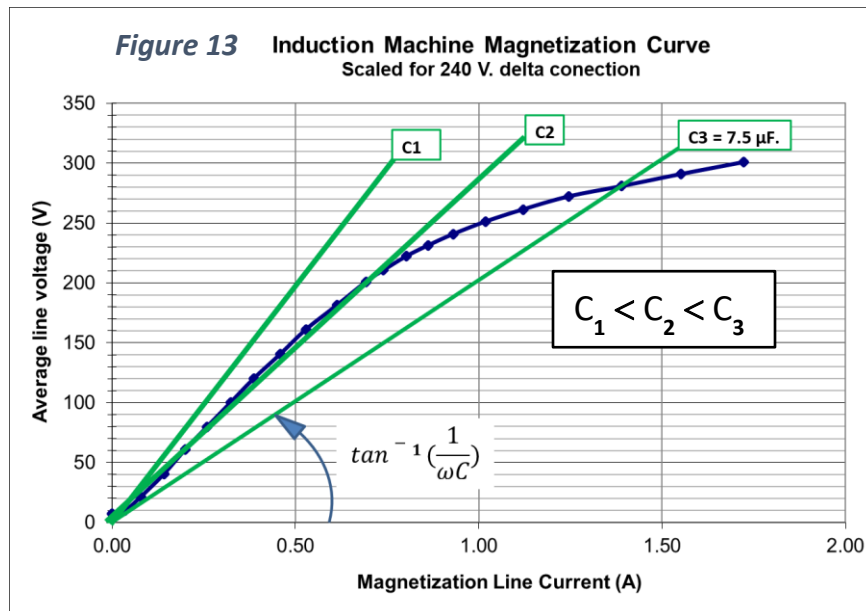

Figure 12 -- Capacitor voltage vs current characteristic.

Like the generator's excitation curve, the capacitive reactance will be a straight line passing through zero whose slope is:

$$X_c = 1/\omega C$$

With sufficient capacitance, the impedance of the capacitors equals the magnetizing impedance. The machine and capacitors will act as a resonant circuit at angular frequency ω . The process of voltage buildup is very much like that of a shunt-excited dc generator. When an induction generator first starts to run, the residual magnetism in the rotor circuit produces a small voltage on the stator windings,



which causes a capacitor current, which increases the voltage. This process continues until the until the iron core is saturated and the voltage is fully built up. Since the capacitor voltage characteristic is a straight line, it can intersect the magnetization curve. If the generator's magnetization curve and the capacitive reactance's straight line are plotted on the same scale, the intersection of the two curves is the final voltage build-up point. The slope of the line to any point on the generator's curve gives the gives the capacitive reactance required to produce that no-load voltage [14]. In Figure 13, C1 is inadequate to excite the machine, as it does not intersect the curve. The machine will be excited to some voltage at C2 but will not give rated load. When load is applied, the voltage will collapse. The intersection point must be in the saturated region, which will give rated load and power. With the proper capacitance C3 and residual magnetism, the voltage will build up when the generator is turned at synchronous speed by the prime mover (figure 14).

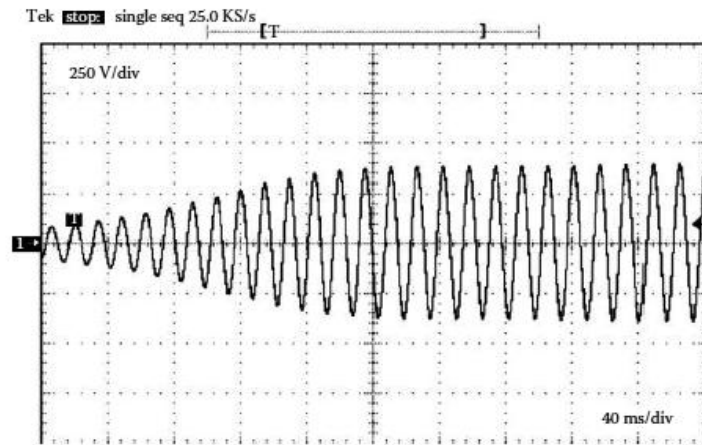

Figure 14 -- SEIG voltage buildup with proper C on each phase [2].

The “cut and try” way to determine C:

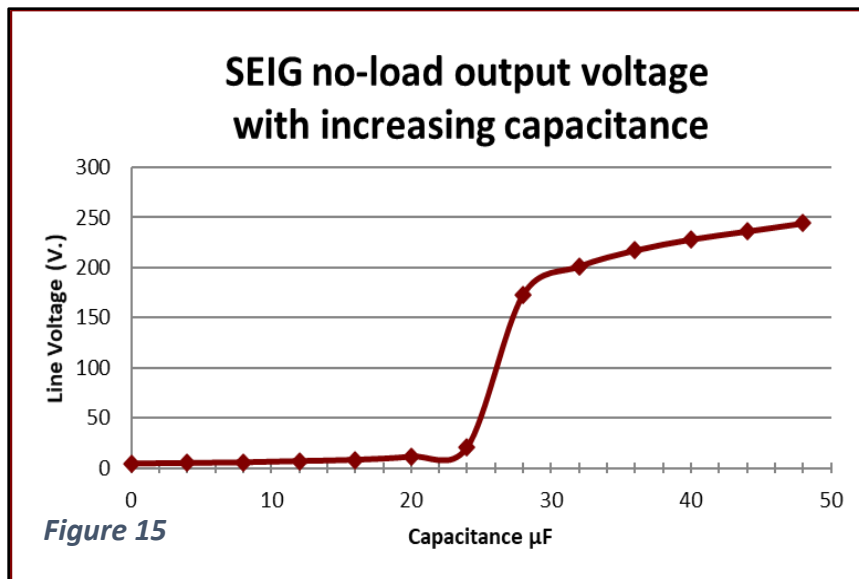

Figure 15

Apply increasing capacitance in star or delta to the SEIG driven at synchronous speed without load. Suddenly, the machine will build up voltage (figure 15). Increasing the capacitance increases the output voltage.

Easiest way to determine C. Measure the no-load current with the machine connected as a three-phase motor and use this to calculate the capacitance. The no-load current $I_{n.l.}$ measured is almost all magnetizing current, as the real losses (friction, windage, hysteresis and eddy currents) are low. In this example:

$$I_{\text{phase}} = I_{n.l.} / \sqrt{3} = 0.713 \text{ A.} / \sqrt{3} = 0.411 \text{ A.}$$

$$C = I_{\text{phase}} / (2 \pi f V)$$

$$= 0.411 \text{ A.} / 6.28 \times 60 \times 207 \text{ V} = \underline{5.27 \mu\text{F}}$$

(For each of 3 capacitors to give rated voltage).

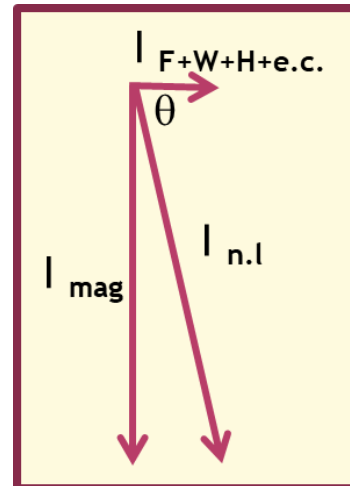

Figure 16 -- No-Load current

Now you have the value of C for normal three-phase operation. The capacitors can be connected in either Wye or Delta:

$$C_{\Delta} = C_Y / 3$$

The necessary additional capacitance for rated load can be determined by experiment. In this case "C" was increased to 7.5 μF to give full load (Figure 13).

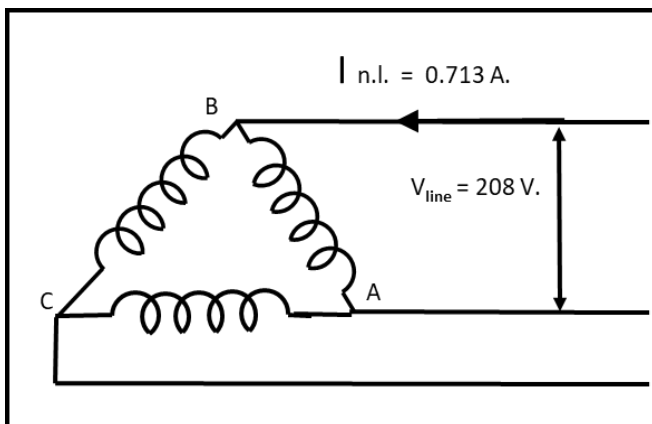

Figure 16 -- Measured no-load current to give SEIG excitation.

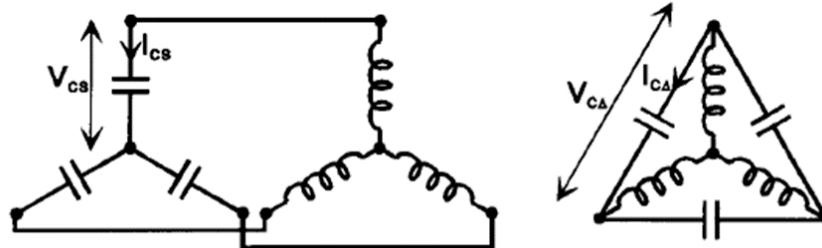

Figure 17 -- Star and delta connection of excitation capacitors. [11]

The Special case of the self-excited induction generator – The C2C connection.

The preferred approach to providing a single-phase supply for resistive loads is to use a three-phase induction motor as a single-phase generator. Because the phase currents will be unequal, the generator must be de-rated by a 20%, unless the "C2C" connection is used (figure 18). It can be shown that for a purely resistive load, if the generator is connected in delta and the following condition is met:

$$I_r = \sqrt{3} I_c, \text{ where } I_r \text{ is the load current and } I_c \text{ is the capacitor current...}$$

... then the C-2C connected generator behaves as a balanced three-phase machine. An equivalent equation is:

$$P_{load} = \Sigma Q / \sqrt{3}$$

where ΣQ is the total capacitor reactive power, and P_{load} is the power dissipated in the load.

Figure 18 – Single phase generation from a three-phase generator using the C-2C method. [11]

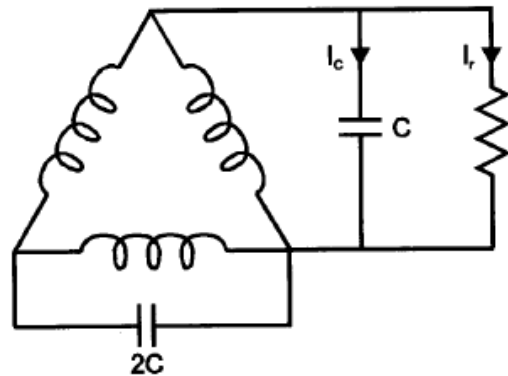

See these references for a complete explanation of the C2C method. [10], [11].

It is vital to ensure the correct direction of the rotation of the machine associating to the phases to which C and 2C capacitors are connected. The rotation is -- “C” (in parallel with the load), “2C”, and no “C”. Below is the result of the C-2C connection for the 1/3 hp lab machine. Note that at low loading the “2C” phase current is higher than the average current, and the “No-C” phase has less. The high current in the “2C” phase requires that the machine be de-rated unless either of the previous equations are met:

$$I_r = \sqrt{3} I_c \text{ or}$$

$P_{load} = \Sigma Q / \sqrt{3}$. In this case $P = Q / \sqrt{3}$ at $388W / \sqrt{3}$ or 244 W. When that condition happens, as in this case, the three phase currents become balanced.

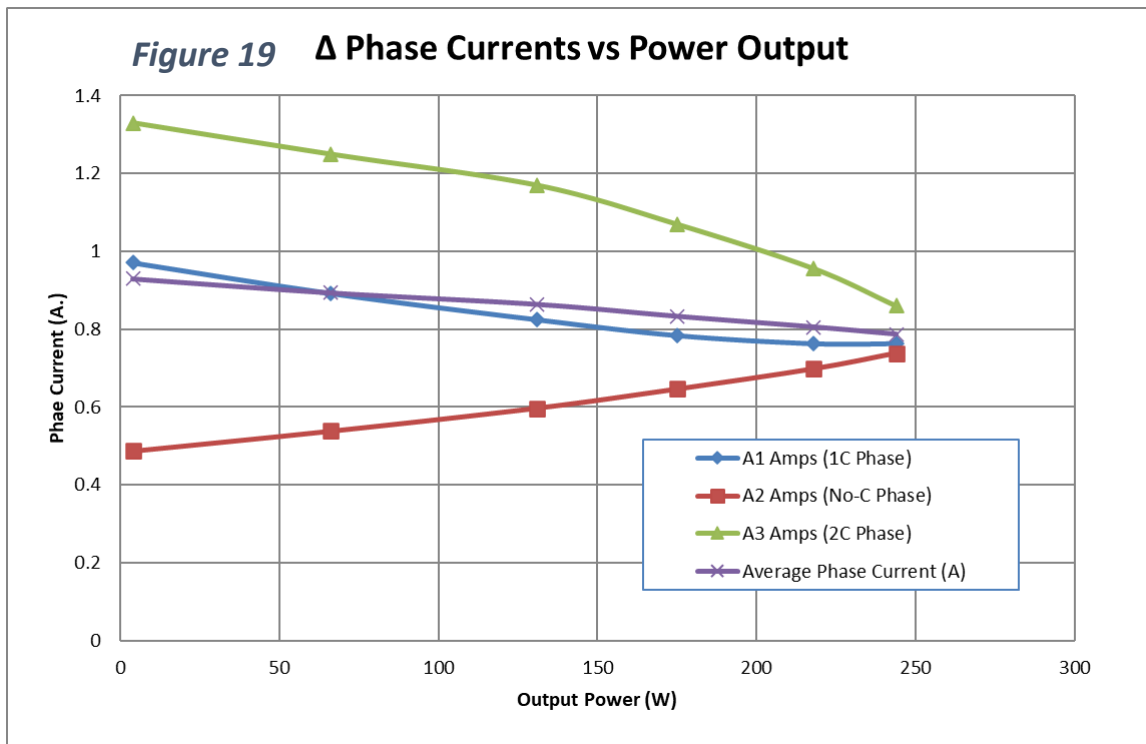

There is a simple way to have this balanced condition if you do not have a load of the correct constant resistance, and that is to use an electronic load controller (ELC). The load is controlled in such a way that the SEIG feels a constant load connected across its terminals. To keep the total load constant, the ELC can compensate for the load variations by automatically varying the amount of power dissipated in a resistive load, known as the “ballast” or “dump” load. To not waste this energy, this ballast load may be a resistive element used for battery charging, water heating, cooking, etc. However, the “fuel”, hydro power to the turbine, is free.

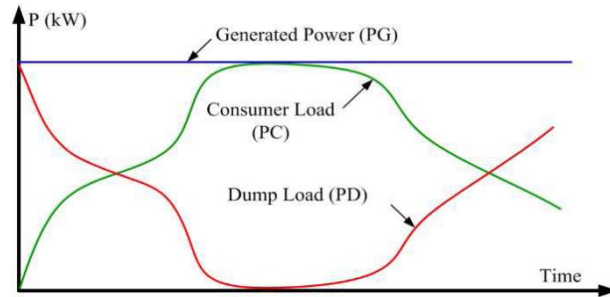

Figure 20 -- Dump and consumer load [12]

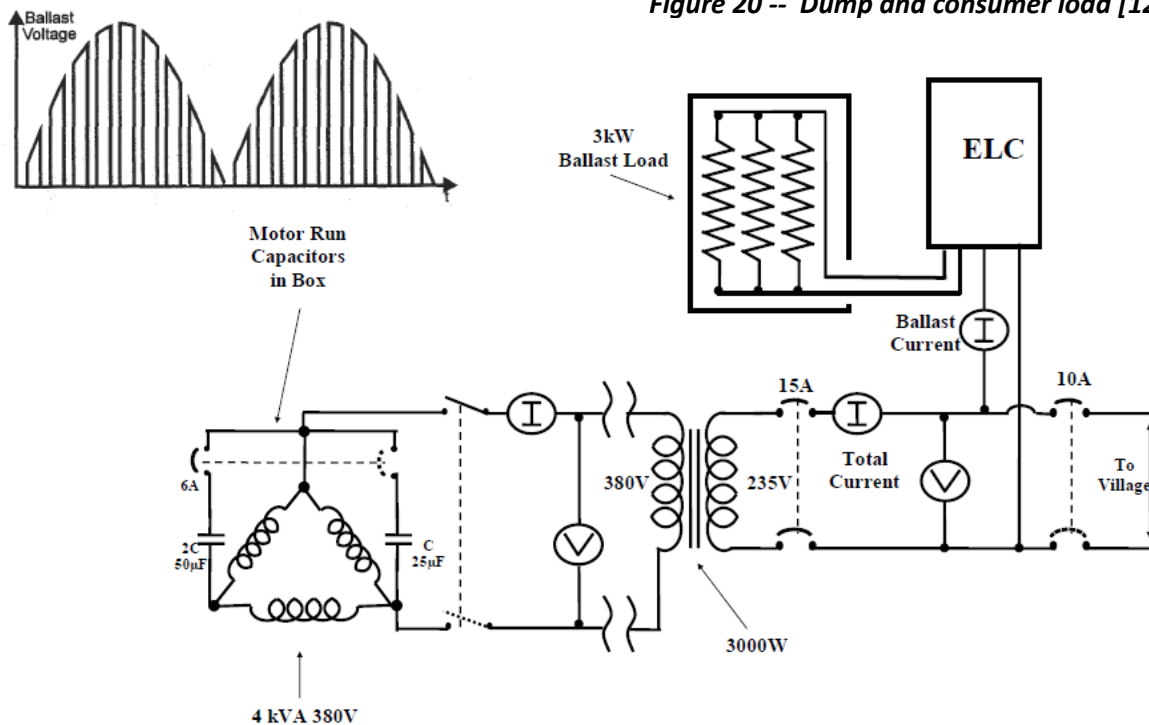

Figure 21 System schematic. The system uses a “C-2C” capacitor arrangement to provide single-phase power from a 3-phase generator. We transmit power at 380 volts, and step it down to 235 volts near the village. A diversion load controller ensures that voltage is constant.

Source: Project report – Huai Kra Thing Micro-hydro project, 19 February 2006, Chris Greacen

Fun fact: This method is reversible – you can use the induction machine and capacitors to generate three-phase power from a single-phase source, where three-phase power is not available. An example would be a hobbyist’s machine shop in a residential garage, where the shop equipment has three phase motors. This device is called a rotary phase converter, and the induction machine is now called an idler. You can make one yourself, as many have done, or buy a manufactured one. You can recognize a commercial rotary converter by the fact that the shaft does not protrude, so no one is tempted to attach a mechanical load on it. But hobbyists will probably buy a used induction motor for the idler.

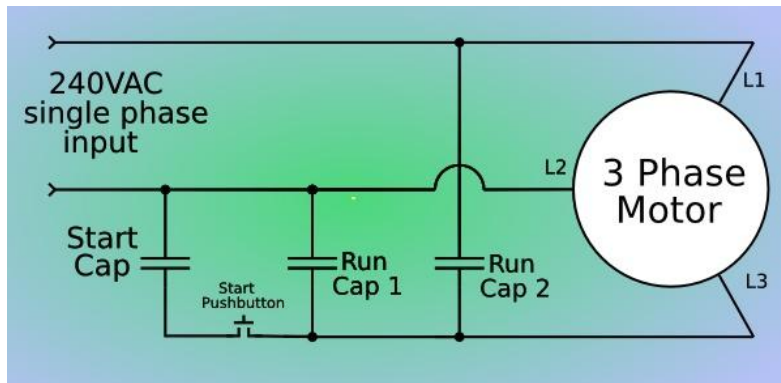

Figure 22 – Connection of a rotary phase converter.
Transwave phase converter wiring , Mig welding guide,
www.mig-welding.co.uk, and Phase-A-Matic Phase converter.

Grid-connected Pumps used as Turbines (PAT). One problem in micro-hydro projects is the high cost of the turbine, for which Pump as Turbine (PAT) is a good solution. Pumps are very similar to turbines, except for the lack of a flow control device (wicket gates). They are usually manufactured in larger quantities and may cost less than a hydraulic turbine, at sizes up to 500 kW. Besides the lower cost, other advantages include availability for a wide range of heads and flows, availability in large number of standard sizes, availability of spare parts such as seals, bearings etc., and easy installation. A centrifugal water pump converts rotational energy from a motor to hydraulic energy (pressure and flow). By running a centrifugal pump in reverse direction to operate as a turbine, the impeller takes the hydraulic energy out of water and converts it into mechanical energy which can drive the induction generator (formerly the motor). When two leads of the attached three-phase motor are switched, the induction machine turns in the opposite direction and acts as a generator and the pump becomes a turbine as the flow is reversed. Many times, pump manufacturers have not tested the pumps in turbine mode, and do not have the necessary curves for the best operating point. Because pump catalog performance curves describe pump duty, not turbine duty, the result can be an oversized unit that fails to work properly unless the manufacturer makes correction factors available that convert turbine performance characteristics to pump characteristics [13] [14]. Since the pump is designed for that application, not as a turbine, a PAT system has lower efficiency.

Illustrating the concept of the different sizes of pumps and turbines used in the same hydraulic situation, on the right in Figure 23 is a booster pump piped in series with the main pump to allow the unit to overcome the head and pump water. Only the main pump/turbine on the left is used in the generator mode.

The City of Boulder has two reversible stations that can be operated as either motor/pump or generator/turbine modes. A study revealed that pump-turbines could be installed which would reduce pressure and generate electricity as water flowed downhill by gravity during normal operation. This equipment could be reversed and used as a pump during emergency conditions if the water supply to Boulder's high-pressure zone was interrupted. The additional cost for generating capability was \$110,000 of a total \$300,000 invested at the Maxwell pump-generator site. Thus, hydro generation was added for a relatively small cost [4]. The Maxwell pump/turbine and transfer switch are shown here in Figure 23. Water flow is shown for the turbine/generator operation. In both pump and generator modes, power factor correction capacitors are utilized.

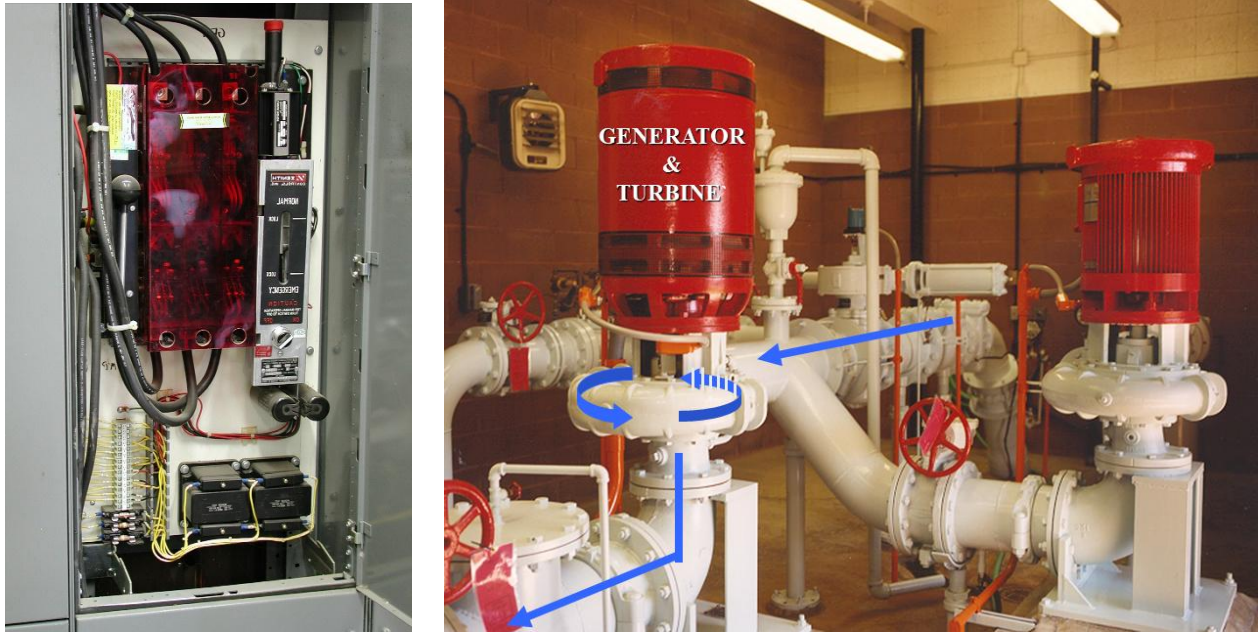

Figure 23 -- Maxwell 80 kW hydro and pump station showing transfer switch.

Hydraulic turbines have wicket gates designed to regulate the flow, which pumps do not. Using a pump as a hydraulic turbine should be restricted to situations where the flow is constant. It is possible to put a

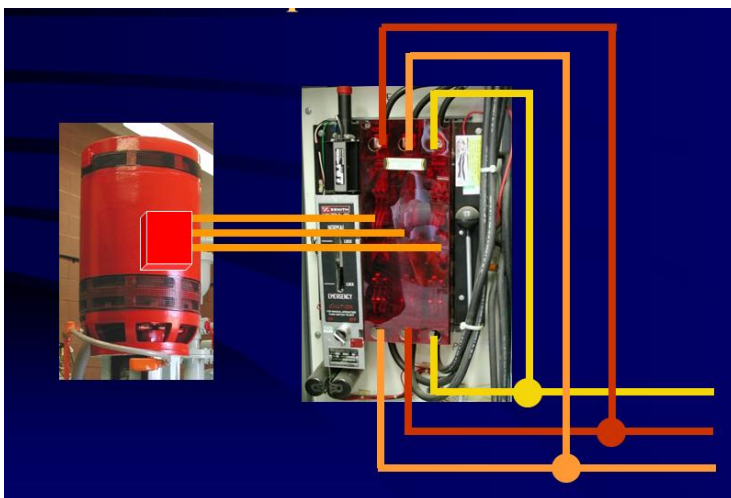

Figure 24 -- Maxwell hydro transfer switch connection.

throttling valve in series with the turbine to regulate the flow, but the pressure drop across the valve wastes energy. Two of Boulder's stations discharge into a reservoir, so the reservoir water level resulting from the turbine flow can be regulated by just switching the units on and off. Sometimes two turbine/generator units are installed in parallel, often of unequal sizes. Then, for example, you can get 1/3, 2/3 or 3/3 flow through the station by bringing on either one or both units. A remotely controlled

transfer switch can be used to switch two of the three-phase motor leads to reverse the direction for generator mode. Transfer switches are three-pole double throw switches that are normally used to switch between regular power and standby power. The transfer in this case is the process of shifting the motor/generator's connection to the power source from the A-B-C to A-C-B, and vice versa. In this case, the center poles are connected to the motor/generator, with the incoming line connected to the two switched connections. Two phases are reversed on one of these connections (Figure 24).

Zero Crossover Switching.

Besides the normal 6X inrush, there can be a very high inrush current when the generator is placed online. The same situation can happen when energizing a transformer or induction motor, and it depends on the residual magnetism in the core, and the magnitude of the voltage at the time the machine is connected to the system. When the core magnetization and the voltage are out of sync, the magnetic core of the generator and transformer are placed in deep saturation, and a magnetic transient

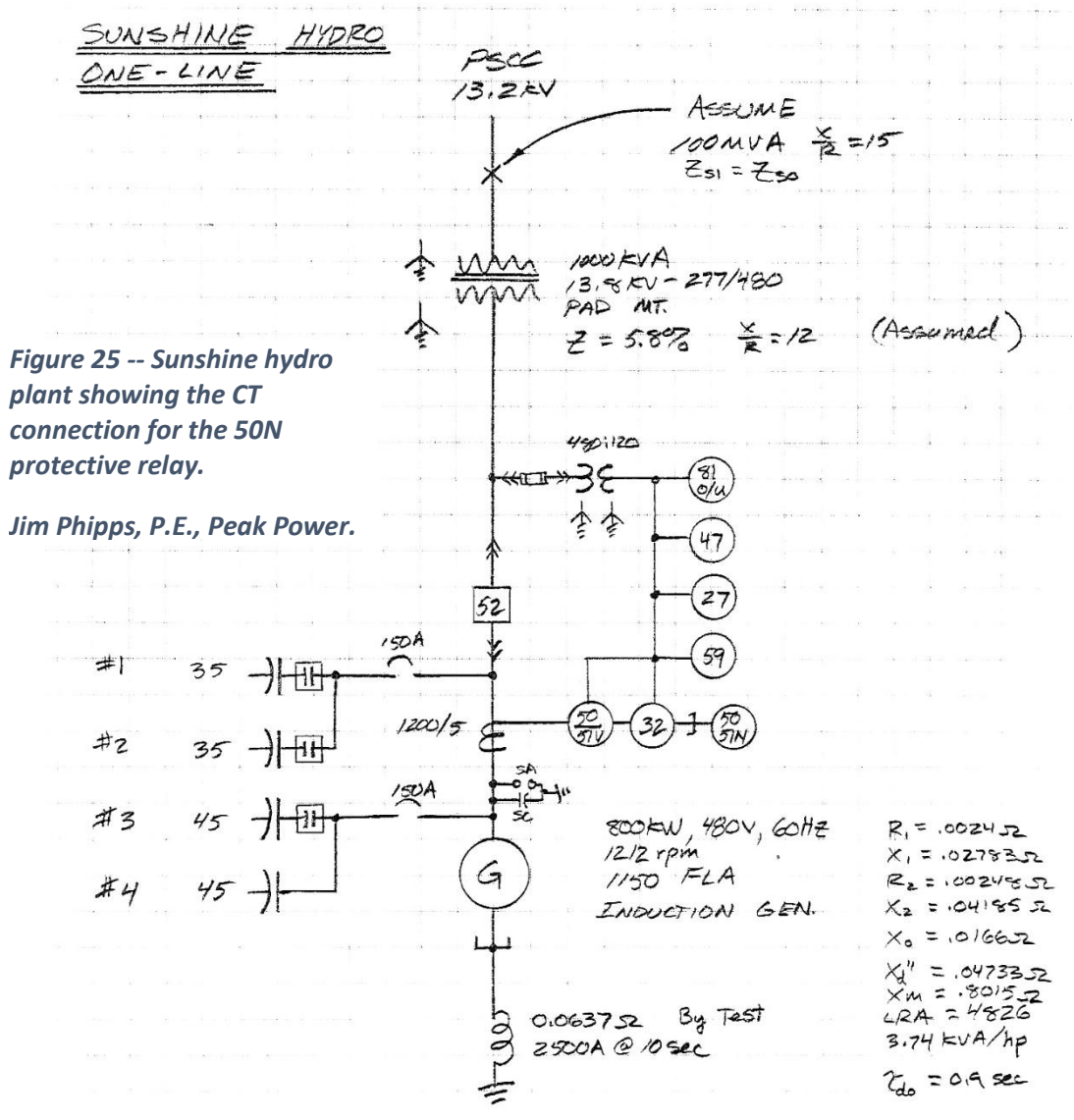

Figure 25 -- Sunshine hydro plant showing the CT connection for the 50N protective relay.

Jim Phipps, P.E., Peak Power.

occurs, drawing a large amount of current into the machine. The worst inrush occurs when residual flux is left in the machine's core and, counter-intuitively, when the voltage is near zero and rising positively. This is called "crossover switching". Energization at peak voltage results in little or no surge. Since the flux is the time integral of the voltage, the positive voltage creates positive flux that adds to the residual flux already on the transformer core. [22] [9]. The result is an inrush current that can exceed the normal full-load current by ten to forty times.

An example of zero crossover switching. The City of Boulder has an 800-kW induction generator that would trip or randomly when energized due to the operation of a 50N ground overcurrent relay. According to the standard *Recommended Practice for Protection and Coordination of Industrial and Commercial Power Systems - IEEE Buff Book*, the 50/51N is "ground fault protection where the relay coil is connected in the residual CT circuit" – i.e., "the neutral (residual) circuit of three individual phase current transformers (CTs) wired in a WYE." The protective scheme had a 1200/5 current transformer on each phase of the generator, which provided current to several relays as shown in Figure 25.

There was no physical CT on the neutral itself. The secondary of the three CTs were combined so that the 50/51N relay saw the sum of the three individual CTs. Under balanced conditions, there would be no current through the 50/51N. Any current through the 50/51N would reflect unbalanced current going to ground. For the troubleshooting test, Engineer Jim Phipps placed a CT on the neutral, as well as monitoring the existing 1200/5 CTs, all connected to a recording oscilloscope. When the saturated CTs were summed, the resulting "CALCULATED" current exceeded 2.5X PU which was much higher than the actual "MEASURED" neutral current, as show in Figure 26. The combined CT saturation produced enough residual current to trip the 50N relay.

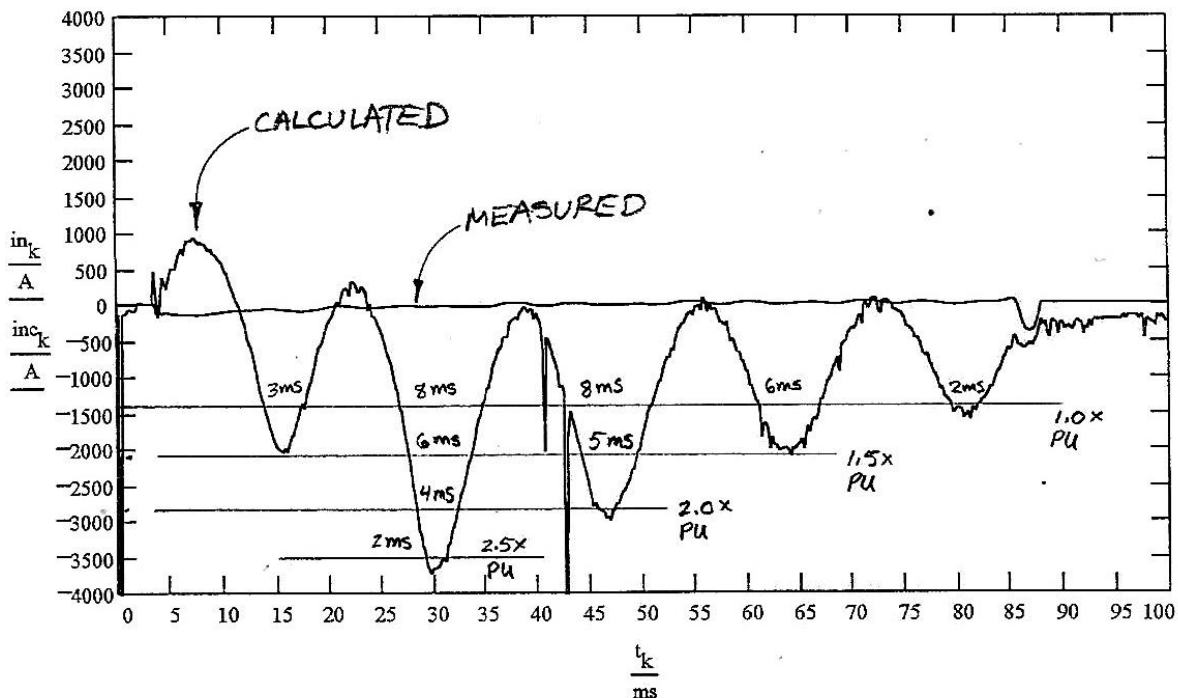

Figure 26 Measured and calculated neutral current (A) vs. time (ms)

Doubly fed induction generator. A more recent application of the induction generator is the use of the “doubly fed” wound-rotor induction generator (DFIG), which is especially helpful for wind generator applications since it can harvest energy at various wind speeds. This variable-speed function replaces the old use of the wound-rotor motor which had external resistors for speed control. Remember that with any induction machine, the rotor magnetic field and the stator magnetic field both rotate at synchronous speed, even though the rotor turns asynchronously. But normally, for the singly fed squirrel cage rotor, the difference in speed due to the slip is very small. In the case of the old wound-rotor machine with external resistors, the extra external resistance shifted the torque-speed curve to the left, which resulted in high slip and a much lower rotor frequency and speed. For example, if the slip was 30%, the rotor frequency was:

$$n_m = (1-s) n_{sync} = (1-0.3) \times 60 = 42 \text{ Hz.}$$

The electronic AC/DC/AC converter for the DFIG can feed the necessary three-phase frequency (in this example 42 Hz) directly to the rotor through the slip rings without the excessive I^2R losses in the old-style external resistors.

But the DFIG can do much more than vary the rotor speed. The DFIG stator is connected directly to the grid, and the machine’s wound rotor is connected to the grid via a bi-directional “back-to-back” voltage source converter that can be controlled for frequency, phase, and voltage. The AC-DC-AC converter consists of two converters, a rotor-side converter (RSC) and grid-side converter (GSC). Since DFIG is fed on both stator and rotor, it is called a doubly fed induction generator. The back-to-back arrangement of the converters provides a mechanism of converting the variable voltage, variable frequency output of the generator (as its speed changes) into a fixed frequency, fixed voltage output that matches the grid. The converters only supply the DFIG rotor circuit, so they only need be rated to handle the rotor power – typically about 30% of the generator’s total power [20]. The smaller the range of the operating slip, the smaller the required power converter. The generator operates in four quadrants around the synchronous speed. Therefore, it can easily operate in motoring mode, for example, for pumped hydro applications if the inverter is bi-directional [16].

Cartesian coordinate system

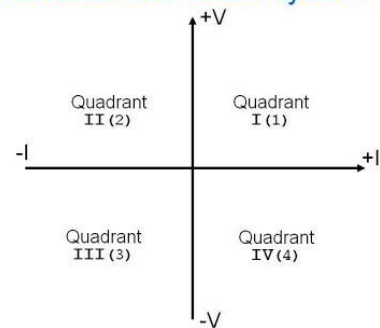

Figure 2

Figure 27 -- Four quadrant power supply [21]

The stator’s magnetic field rotational speed can either be increased or decreased by changing the phasing of the ac to the rotor. In this way, the stator’s magnetic field’s rotational speed can match the utility’s frequency despite variations in the rotor speed. Thus, the rotor speed can vary to follow changing winds without affecting the stator’s grid-connected output frequency. The control system also controls the wind turbine itself, controlling the pitch angle of the wind turbine blades. By also tracking the optimum generator blade tip-speed ratio, called the turbine power coefficient or the C_p , it can extract maximum wind energy. Control of the rotor speed also absorbs gusts of wind that would otherwise produce spikes of electrical power output and produce high mechanical stress on the equipment.

The main objectives for the GSC are to keep the dc-link voltage constant at unity power factor, regardless of the magnitude and direction of the rotor power, and to provide a specified reactive power to the system. Between the two converters a dc-link capacitor filters out ripple in the dc link.

The rotor-side converter (RSC) applies the voltage to the rotor windings of the DFIG. The rotor-side converter is usually controlled to have optimal C_p , and it generates or absorbs reactive power just like a synchronous generator. This is a very useful feature since the conventional induction generator always requires reactive power support. The RSC controls the rotor so that the machine's shaft develops the desired torque therefore must control the magnitude, frequency, and phase of the applied rotor current.

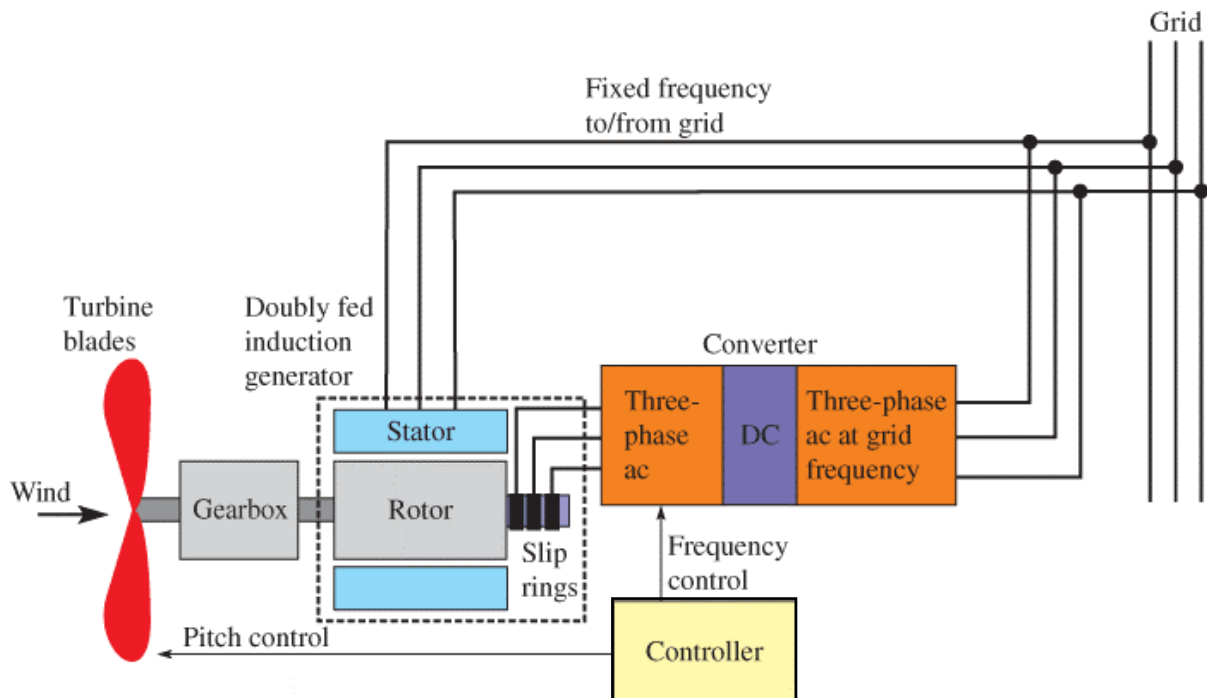

Figure 27 - Doubly fed induction generator for a wind turbine using a wound rotor. [15]

A doubly fed induction generator requires full synchronization before connection to the grid, like a synchronous machine. In a DFIG system, synchronization is made electrically by controlling the rotor current vector position and matching it to the reference stator voltage position or to the rotor position [23]. This provides faster synchronization than in a synchronous generator unit, because the rotor shaft position is unimportant [18].

- [1] Pankaj K. Sen and John P. Nelson, "Application Guidelines for Induction Generators," Proceedings of the IEEE ,pp wc1-5.1- wc1-5.3, 1997
- [2] M. Godoy Simões; F. A. Farret,, Renewable Energy Systems: Design and Analysis with Induction Generators CRC Press, 2004
- [3] B.L. Theraja & A.K. Theraja, A Textbook of Electrical Technology: Volume II: AC & DC Machines, S. Chand & Co Ltd 2005
- [4] Hydroelectricity -- City of Boulder, beta.bouldercolorado.gov/services/hydroelectricity
- [5] Jong-Gyeum Kim and Young-Jeen Park, Reduction of Inrush Current and Voltage Drop by Selecting Optimum Reactors in Induction Generators, 2018 21st International Conference on Electrical Machines and Systems (ICEMS) October 7-10, 2018
- [6] A Guidebook on Grid Interconnection and Islanded Operation of Mini-Grid Power Systems Up to 200 kW, Chris Greacen, Richard Engel & Thomas Quetchenbach, April 2013, Lawrence Berkeley National Laboratory
- [7] Safety, Interference And Interconnection Guidelines For Cogenerators, Small Power Producers and Customer-Owned Generation, Xcel Energy, August 6, 2020
- [8] *Capacitive Excitation for Induction Generators* by Basset and Potter Electrical Engineering, March 1935
- [9] Self-Excitation of Motors by C.F. Wagner, IEEE Transactions February 1939, VOL. 58, p.47
- [10] Ekanayake, J.B. Induction generators for small hydro schemes. Power Engineering Journal 2002; 16(2):p. 61-67.
- [11] Nigel Smith (Editor), Motors as Generators for Micro-hydro Power, Practical Action Publishing, 2007
- [12] Nan Win Aung, Aung Ze Ya, Microcontroller Based Electrical Parameter Monitoring System of Electronic Load Controller Used in Micro Hydro Power Plant, Journal of Electrical and Electronic Engineering, 2015;
- [13] Kinney, Warnick, Bradley, Dodds, McLaughlin, Miller, Sommers, & Rinehart, EG&G Idaho DOE Micropower Handbook Volume 1, 1983 Doewater 10107
- [14] Tarang Agarwal, Review of Pump as Turbine (PAT) for Micro-Hydropower, International Journal of Emerging Technology and Advanced Engineering, Volume 2, Issue 11, November 2012.
- [15] Linquip Content Management Team, What is an Induction Generator? An Ultimate Guide, <https://www.linquip.com/blog/what-is-an-induction-generator/>
- [16] M. Godoy Simões, Felix A. Farret, Modeling and Analysis with Induction Generators, Third Edition, March 31, 2021, CRC Press

[18] Dominik A. Górski and Grzegorz Iwanski, Asynchronous Grid Connection of a Cage Induction Generator Excited by a Power Electronic Converter, IEEE Transactions on Energy Conversion, Vol. 36, no. 1, March 2021

[19] No author listed, <https://electricalacademia.com/induction-motor/induction-generator-types-working-principle-permanent-magnet-generator-working-principle/>

[20] John Fletcher and Jin Yang (December 30th 2010). Introduction to the Doubly-Fed Induction Generator for Wind Power Applications, Paths to Sustainable Energy, Jatin Nathwani and Artie Ng, IntechOpen, DOI: 10.5772/12889. Available from: <https://www.intechopen.com/chapters/12519>

[21] What is a bipolar (four-quadrant) power supply?
<http://powersupply.blogs.keysight.com/2012/10/what-is-bipolar-four-quadrant-power.html>

[22] Beware of Zero-Crossover Switching of Transformers, no author listed, Tyco Electronics Corporation – P&B, Winston-Salem, NC 27102,
<http://d3i5bpxkxvwmz.cloudfront.net/articles/2011/07/14/crossover-current-1310623782.pdf>